



Nesting Cornhole Board Instructions

- First cut the following lengths of 2" x 4":
 - 2 @ 4'
 - 2 @ 45"
 - 2 @ 21"
 - 3 @ 18"
 - 4 @ 12 9/16 " (used for the legs)
- Glue and screw (or nail) the frame together.
 - Make sure the frame is square by measuring from corner to corner diagonally. You should get the same measurement from opposite corners.
 - With both frames assembled, make sure the frame of #2 will fit inside of the #1 frame.
- Cut two pieces of 1/2" plywood - measuring 4' by 2'
 - Lay the plywood on the frames first and pre-drill for screws, this will avoid splintering of the wood on the surface.
 - Attach plywood to the #1 frame.
 - Measure in from each edge of the second piece of plywood 2 1/4"
 - Mark the measurement with a pencil, and then draw a line between the marks. You should nest the two frames and use the edge of #1 to align #2. Attach #2 frame to the plywood using these lines.
- Cut circle in proper location.
 - There are several ways to cut the circle (for the hole). Choose the way in which you are familiar and have the proper tools.
- Attach legs to frame.
 - Using measurements from the plans mark, where center of hole should be.
 - Using a jigsaw or other means cut a 1.5" radius on the end of your legs.
 - Drill holes in legs and frame.
 - Bolt legs to frame. Use a fender washer on both sides of leg to prevent legs from sticking when you paint them.
 - Wing nuts should be used on the legs to board #1 because the legs have to be removed and stored to nest boards.
- Paint or stain to your liking.

Good luck and happy cornholing!



NESTING CORNHOLE BOARDS

BOTTOM VIEW

CORNHOLE
PLAYERS.net

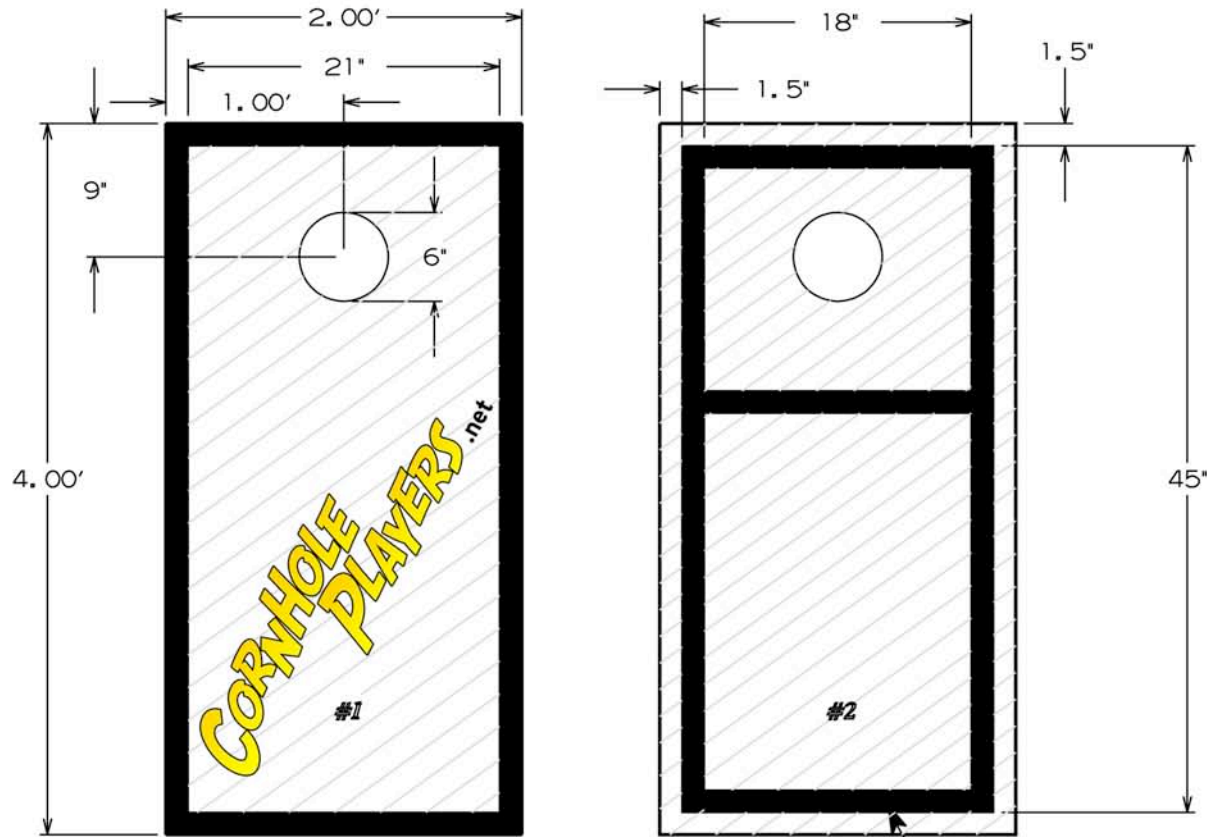

Both pieces of plywood should be 4' by 2'
the frame of board #2 is smaller to accommodate nesting.
For a lighter set, you can use other framing material instead of 2" x 4",
but you have to make the measurements on board #2 different.

1/2" plywood

2" X 4"



NESTING CORNHOLE BOARDS

ISOMETRIC VIEW

Wing nuts should be used on this board because legs will have to be removed and stored to nest boards.

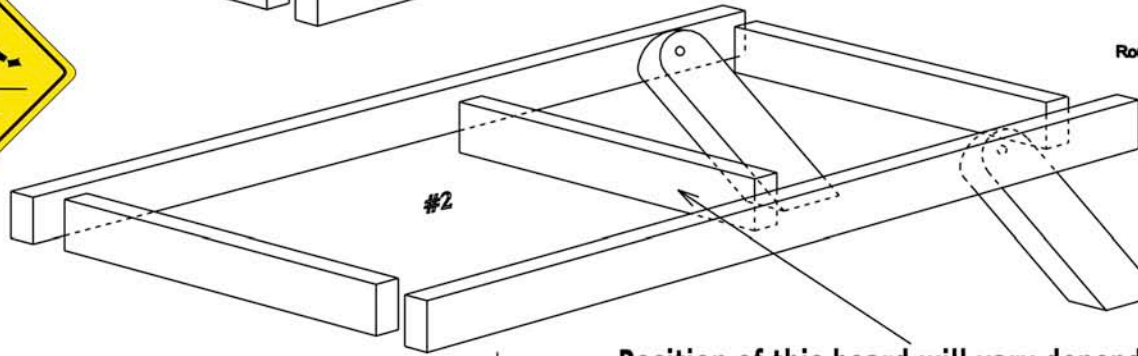
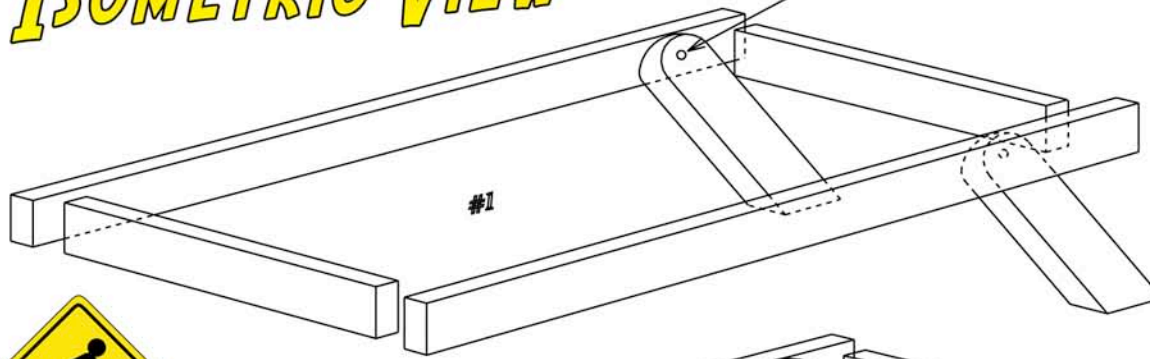

Detail of leg

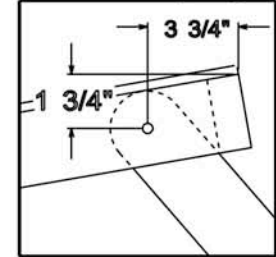

Use bracing to act as a stop

Round top of leg so that it will pivot.

Cut leg at an angle so that it will sit flat.

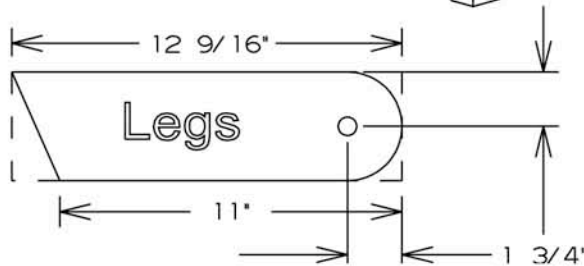

Position of this board will vary depending on how much storage space is needed. Make sure to leave room for legs to fold.

CORNHOLE PLAYERS.net

Boards will stack in each other for storage and transport. With boards stacked, bags and such can be stored between the boards.

Handles and latches can be added as needed for transport.

Legs have to be initially cut to 15 3/4" then have the angle cut.

Legs on board #1 have to be removed to nest boards.

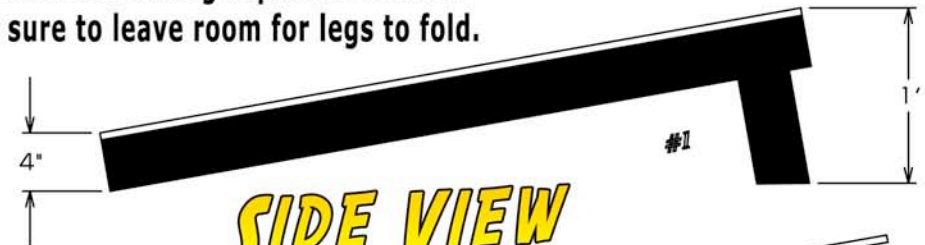

SIDE VIEW

